

Boundary Wall Elevation

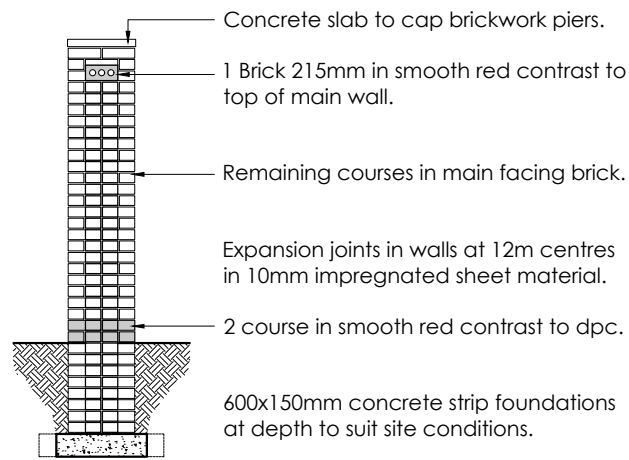

Boundary Wall Section

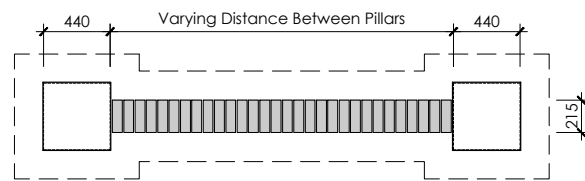

Boundary Wall Plan  
Boundary Type A  
1.8m High

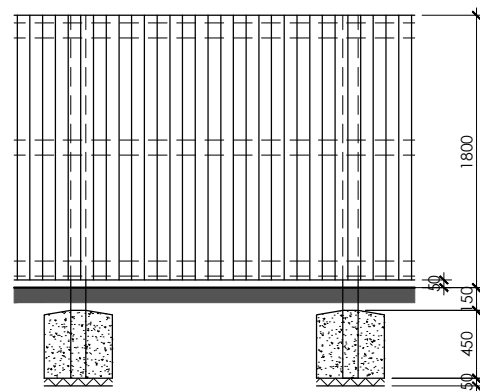

Elevation

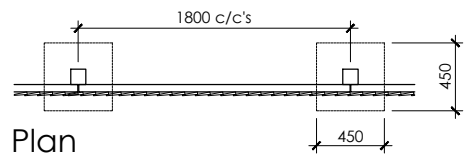

Plan  
Feathered Edge Fencing

Boundary Type B  
1.5m High  
1.8m High

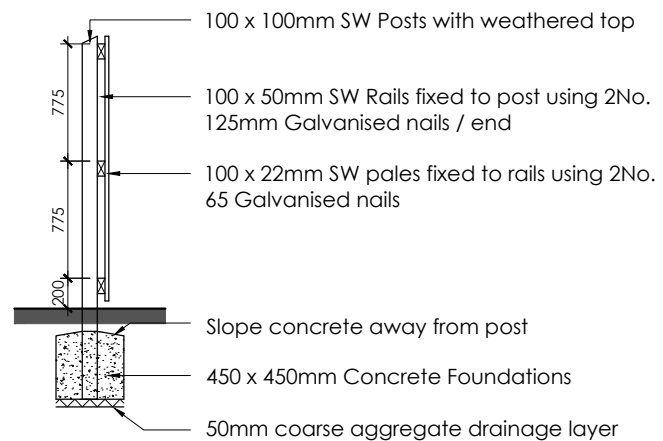

Section

Note: All timbers to be pressure treated

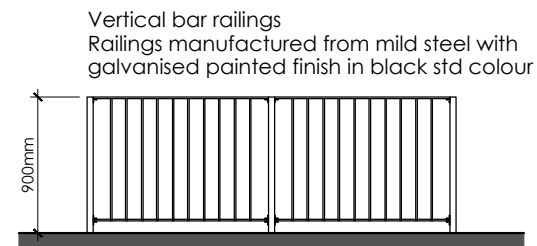

Typical Elevation

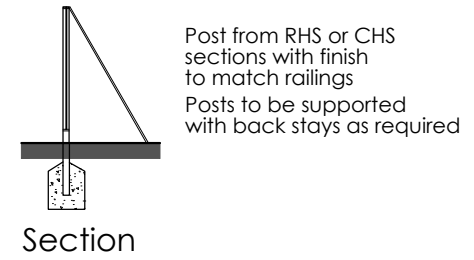

Section

Boundary Type C  
0.9m High Railings  
1.8m High Railings

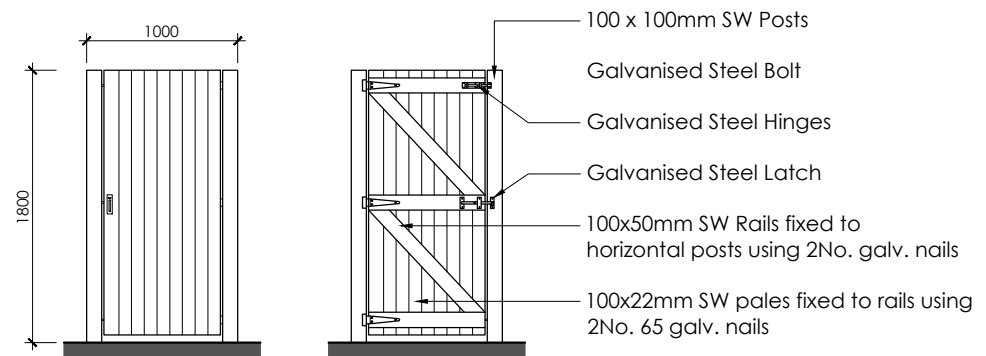

Front View  
Rear View  
Access Gate Details

Note: All timbers to be tanalised, apply min. 2 coats of Timber Preservative

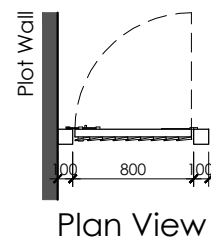

Plan View

REV	DATE	DRAWN	DESCRIPTION
-	-	-	-
TITLE:			
<b>BOUNDARY DETAILS</b>			
 <b>Breck Homes</b> 20 Sceptre Court Bamber Bridge Preston PR5 6AW tel: 01253 587 010 web: www.breck.co.uk/homes hello@breck.co.uk			
PROJECT:			
SOUTHDEAN ROAD, KNOWSLEY			
DATE:	SCALE:	JOB REF:	DRAWING NUMBER:
SEPT.25	1:50 @ A3	-	P04 Southdean Road / Boundary Details
REV:			
-			

NOTE : THIS DRAWING TO BE READ IN CONJUNCTION WITH THE BOUNDARY TREATMENTS PLAN - DRAWING - P03